

Flat axial wind turbine

(patent pending)

F-A-W-T = Flat axial wind turbine

model of the flat axial wind turbine



CONTENT :

1. Principles to design a new turbine for more efficient use of wind
2. Basis - how it works in the wind
3. Structural types of flat axial wind turbines
4. Protection of flat axial wind turbines
5. Advantages of the flat axial wind turbine
6. Use of the flat axial wind turbine

Conceptual content of the turbine name:

Flat - in the name it means that the air hits the full impermeable circular plate to its entire surface.

Axial - in the name means that the air hits the circular plate of the turbine frontally - axially.

Wind - in the name it means that the medium of the turbine is wind.

Turbine - in the name it means that its task is to produce energy by means of a rotary blade machine

1. Principles to design a new turbine for more efficient use of wind

- a. changing the direction of the air flow from the centre of the circular plate to the edges of the circular plate when the air surrounds the circular plate in its perpendicular position to the direction of the wind
- b. increasing the speed of the generator without the use of gears with two-ring counter-rotating plates
- c. using the aerodynamic lift force of the aerodynamically shaped leaves for the rotary movement of the plates
- d. cutting the top edge of the leaves at approximately a 45 degree angle always in the direction of rotation of the plate
- e. eliminating the air resistance when turning the turbine by placing the leaves close behind each other in the direction of rotation
- f. using the advanced stationary elements to direct and induce a rotary air flow
- g. increasing the speed of the wind flow through the turbine when using a confusor

2. Basis - how it works in the wind

The basic innovative idea in the design of the flat axial wind turbine is to use the air flow directed from the centre of the circular plate to the edges of the circular plate, while the circular plate is located in a perpendicular position to the direction of the incoming wind. With this position of the circular plate, the air flow hitting the plate has nowhere to escape and, due to the increased pressure in the central part of the plate, it flows towards its edges to places of lower pressure with increasing speed. The structural solution of the flat axial wind turbine enables the rotating movement of the rotating circular plate, or the counter-rotating movement of two circular plates caused by the force of the wind, and to transfer the obtained mechanical energy to a generator to produce electricity, or to use it in another way.

air flow around the turbine

FIG. 12

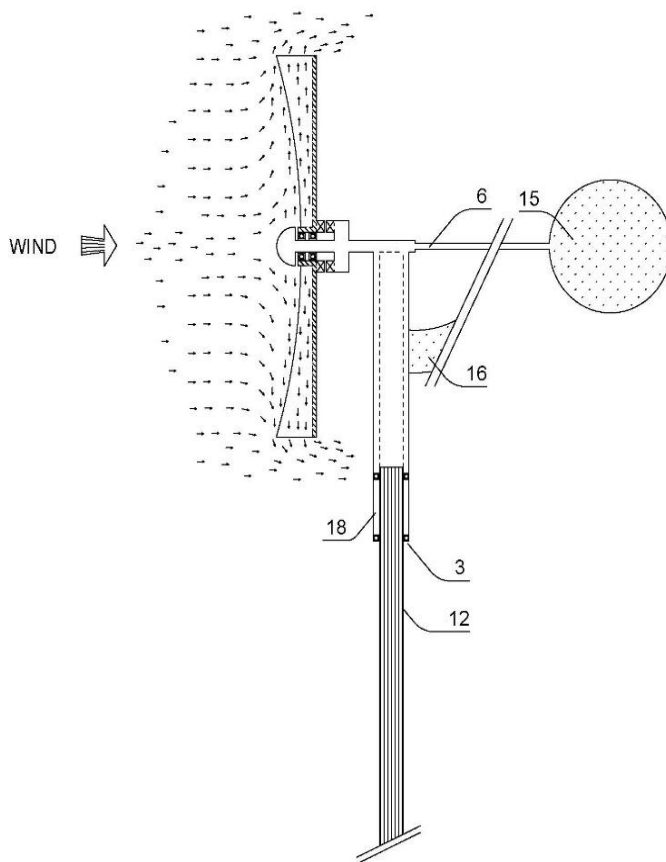
Reference marks

- 1 – rotating circular plate
- 2 – counter-rotating circular plate
- 3 – bearing of the rotating plate
- 4 – leaf of the rotating plate
- 5 – stationary grooved cone
- 6 – horizontal rotating structural rod
- 7 – generator
- 8 – pike
- 9 – supporting frame of the external stabilization of the circular plate
- 10 – peripheral wheel of the external stabilization of the circular plate
- 11 – supporting ropes
- 12 – mast
- 13 – transverse wheel of the external stabilization of the circular plate
- 14 – rod structure of the mast fastening
- 15 – spherical direction indicator
- 16 – surface direction indicator
- 17 – mast base
- 18 – supporting tubular structure
- 19 – structural plate
- 20 – swivel joint
- 21 – confusor
- 22 – frame ring
- 23 – swivel hinge
- 24 – load
- 25 – rod structure of the rope fastening

The rotary circular plate is constructed as a solid impermeable plate, which has arc-shaped rotary plate leaves rigidly attached to it all around, going from the centre of the rotary circular plate to its edges, while these leaves have the shape of an aerodynamic curved wing, and at the same time, they are cut from the upper side at an angle of approximately 45 degrees in the direction of rotation of the plate. The rotating movement of the circular plate causes the movement of air hitting the perpendicularly placed rotating circular plate, while the air must change the direction of flow from the centre of the circular plate to its edges under the pressure of the next incoming air, and this flow passes through the gaps between the curved leaves of the rotating plate and hits the walls of these leaves, causing the rotation of the entire circular plate. In this air flow, the law of action and reaction operates between the air and the leaves of the circular plate, because the air flow leaves this plate in a tangential direction relative to the circular plate due to the influence of the curved leaves of the rotating plate and causes it to rotate. In fact, due to the drifting speed of the circular plate, the air leaves the circular plate in the direction of the centrifugal force depending on the speed of rotation of the plate. At the same time, an aerodynamic flow effect is applied between the leaves, where a negative pressure is created on the side of the leaf with the longer side of the leaf similar to the wing of the aircraft and contributes to the rotation of the entire circular plate. The rotating circular plate with the leaves creates very little air resistance to rotation, because the leaves of the rotating plate in the direction of rotation are located close behind each other and create an aerodynamic shadow.

This basic principle of the creation of rotational movement and the subsequent use of energy from the rotation of the circular plate of the flat axial wind turbine can be amplified by adding other structural parts improving the efficiency of the entire turbine:

- by adding a counter-rotating circular plate with a two-rotor generator which doubles the speed of the generator
- by adding a central stationary grooved cone with arch-shaped grooves facing the direction of rotation of the rotating circular plate, creating a radial flow in the centre of the plate

- by adding stationary leaves directing the air flow around the circumference of the circular plate in the direction of rotation of the rotating circular plate, creating a radial flow around the edges of the plate
- by adding an advanced confusor which increases the effective working area of the used wind.

The purpose of the last three methods of improving the efficiency of the entire turbine is to increase the speed of rotation of the rotating circular plate by means of the non-rotating parts of the turbine. The connection of the generator and the protection of the turbine against strong wind is described in the text for the individual design types of the flat axial wind turbine.

3. Structural types of flat axial wind turbines

There are several design methods for the implementation of flat axial wind turbines according to the method of fixing the turbine depending on the automatic rotation of the turbine against the wind, the publication of which exceeds the scope of this information material. In the following text, the basic types of flat axial wind turbines is described.

Description of the structure of a single-ring flat axial wind turbine mounted pivotally on a support mast (shown in view in Fig. 1 and in cross-section in Fig. 2)

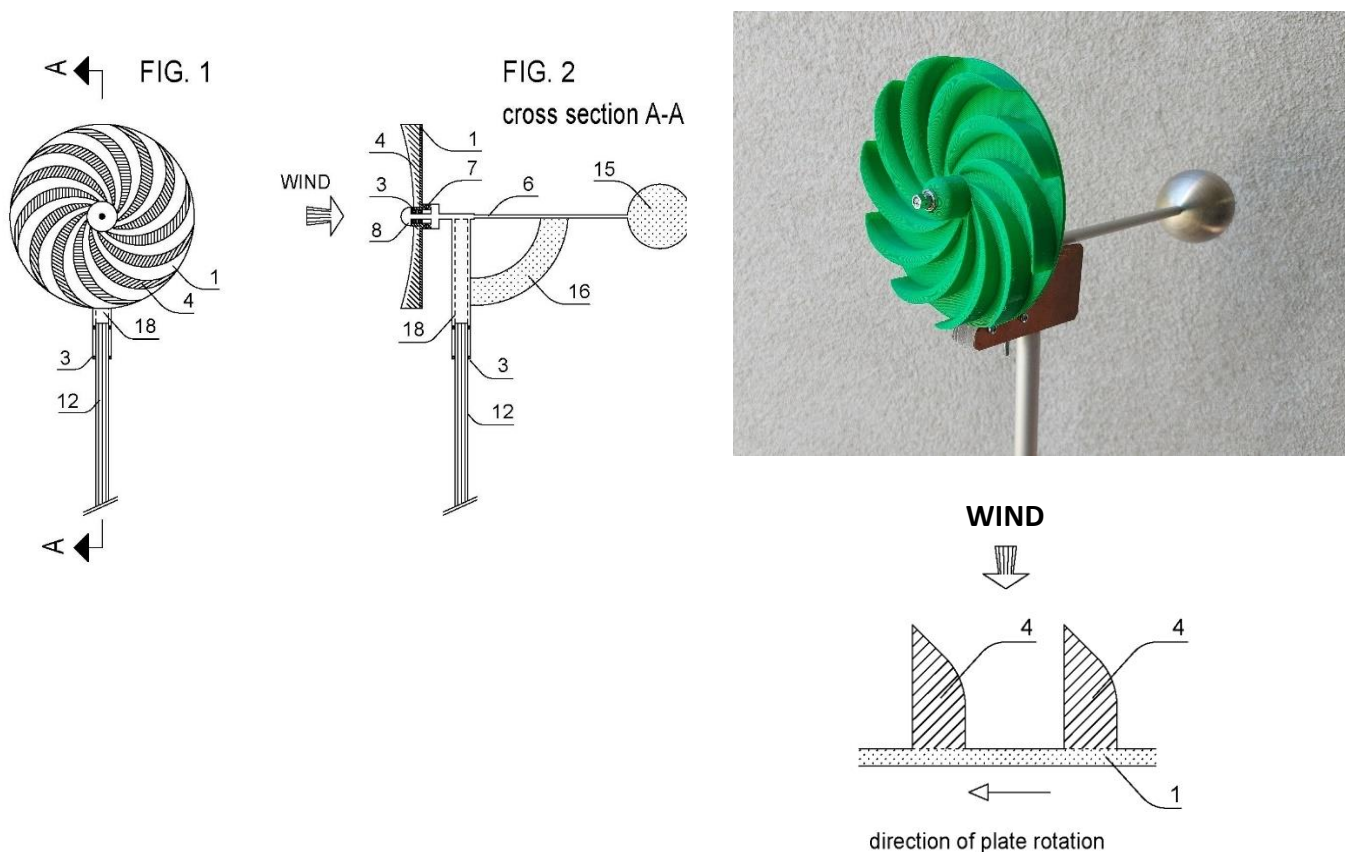

There are three basic structural parts of the single-ring flat axial wind turbine according to their function, and they are divided into supporting parts of the structure that ensure their shape and stability, then into structures that ensure the position of the rotating parts, and the rotating parts that convert the energy of moving air into electrical energy.

The rotating part of the turbine consists of the rotating circular plate **1**, which is impermeable to air, and the leaves of the rotating plate **4**. The rotating circular plate **1** is pivotally attached with bearings **3** to the horizontal rotating structural rod **6**. On the rotating circular plate **1**, the leaves of the rotating circular plate **4** are rigidly attached all around, which have the shape of an aerodynamic curved wing, because they are thicker in the middle part than at the edges where they have a pointed shape and are arch-shaped directed from the centre of the rotating circular plate **1** to its edges. The leaves of the rotary plate **4** are cut from the upper front side at an angle of approximately 45 degrees, inclined at each point of this leaf of the rotary plate **4** in the direction of rotation of the rotary circular plate **1** so that the energy of the moving air hitting the leaves of the rotary plate **4** contributes

to increasing the torque of the rotary circular plate **1**. A rotating part of the generator **7** is attached to the rotating circular plate **1**, the second stator part of which is attached to a horizontal rotating structural rod **6**, a pike **8** is mounted at the it, directing the movement of air from the centre of the rotating circular plate **1** to its edges. Among the parts of the structure ensuring the position of the rotating parts in the correct position in relation to the direction of the air flow in the horizontal plane, there are the supporting tubular structure **18** mounted on the bearings **3** fixed on the mast **12** and the horizontal rotating structural rod **6** with the spherical direction indicator **15** and the flat direction indicator **16**. The flat direction indicator **16** ensures the turning of the flat axial wind turbine in the correct direction, and the spherical direction indicator **15** ensures the same and at the same time it stabilizes the horizontal movement. Among the load-bearing parts of the structure, there is the mast **12** fixed on a massive base.

Description of the structure of a two-ring flat axial wind turbine mounted pivotally on a support mast
(shown in view in Fig. 3 and in cross-section in Fig. 4)

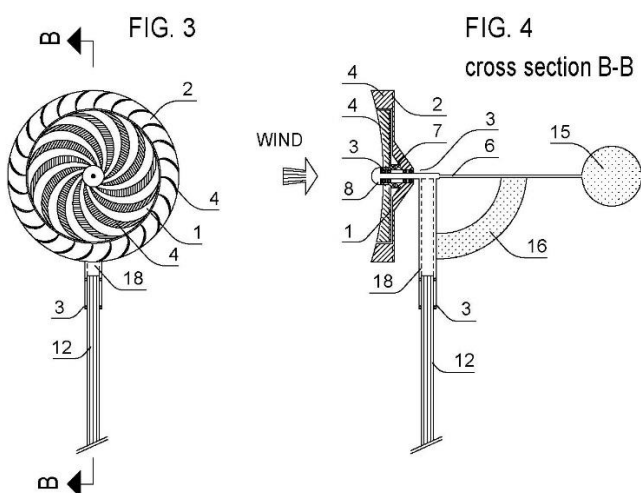

There are three basic structural parts of the two-ring tilting flat axial wind turbine according to their function, and they are divided into supporting parts of the structure that ensure their shape and stability, then into structures that ensure the position of the rotating parts, and the rotating parts that convert the energy of moving air into electrical energy.

The rotating part of the turbine consists a the rotating circular plate **1** and a counter-rotating circular plate **2** which are impermeable to air. The leaves of the rotary plate **4**, whose shape and connection are described in the first design type, are attached to both rotary plates. Both rotating plates are pivotally attached with bearings **3** to the horizontal rotating structural rod **6**. The rotating counter-rotating circular plate **2** is located just behind the rotating circular plate **1**, it has a larger radius and the leaves of the rotating plate **4** are attached from the place where the leaves of the rotating circular plate **1** end, but in the opposite direction to the leaves of the rotating circular plate **1**, thus achieving a counter-directional movement. The first rotating part of the two-rotor generator **7** is attached to the rotating circular plate **1**, the second rotating part of which is attached to the rotating counter-rotating circular plate **2**. Among the parts of the structure ensuring the position of the rotating parts in the correct position in relation to the direction of the air flow in the horizontal plane, there are the supporting tubular structure **18** mounted on the bearings **3** fixed on the mast **12** and the horizontal rotating structural rod **6** with the spherical direction indicator **15** and the flat direction indicator **16**. Among the load-bearing parts of the structure, there is the mast **12** fixed on the base.

Description of the structure of a single-ring and two-ring flat axial wind turbine with a stationary grooved cone pivotally mounted on a support mast
(shown in view in Fig. 5 and in cross-section in Fig. 6)

The description of the structure of the flat axial wind turbine in this example is the same as that given in the previous two design types, with the difference that instead of the pike **8**, a stationary grooved cone **5** is advanced in front of the rotating circular plate **1** which reduces the weight of the rotating circular plate **1**, because the leaves of the

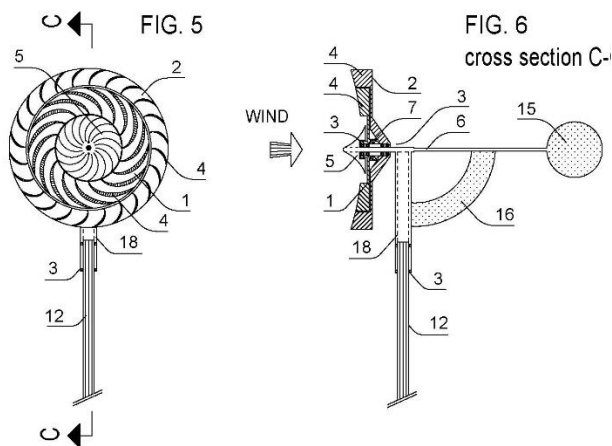

rotating plate **4** are attached only behind the perimeter of the stationary grooved cone **5**. The air flow coming to the rotating plate **1** in the central part already has an initial rotation and increases the turbine power.

Description of the structure of a single-ring tilting flat axial wind turbine pivotally mounted on a support mast (shown in cross-sections in Fig. 15, 16 and 17)

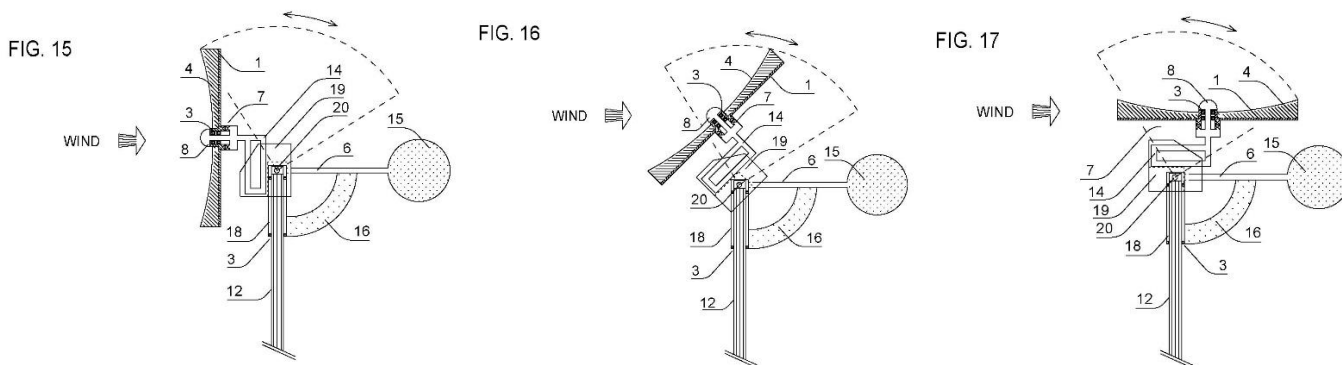

The description of the structure of the flat axial wind turbine in this example is the same as that given in the first design type, with the difference that the rotating circular plate **1** is attached with bearings **3** to the horizontal part of the rod structure **14** of the mast attachment, which is axially displaced by a certain distance from the vertically rotating joint **20** in the vertical direction, and this displacement enables the pressure of the strong wind on the rotating circular plate **1** to automatically tilt it to a horizontal position. The rotating part of the generator **7** is attached to the rotating circular plate **1**, the second stator part of which is attached to the rod structure **14** of the mast attachment. Among the parts of the structure ensuring the position of the rotating parts in the correct position with respect to the direction of air flow in the vertical plane, there is a structural plate **19** with a swivel joint **20** connected to a supporting tubular structure **18**. At the end of the rod structure of the mast attachment **14**, a pike **8** is fitted, which directs the movement of air from the centre of the rotating circular plate **1** to its edges.

Description of the structure of a single-ring tilting flat axial wind turbine pivotally mounted on supporting ropes

(shown in view in Fig. No. 18 and in cross-sections in Fig. No. 19, 20 and 21)

There are three basic structural parts of the single-ring tilting flat axial wind turbine suspended pivotally on supporting ropes **11** according to their function, and they are divided into supporting parts of the structure that ensure their shape and stability, then into structures that ensure the position of the rotating parts, and the rotating parts that convert the energy of moving air into electrical energy.

FIG. 18

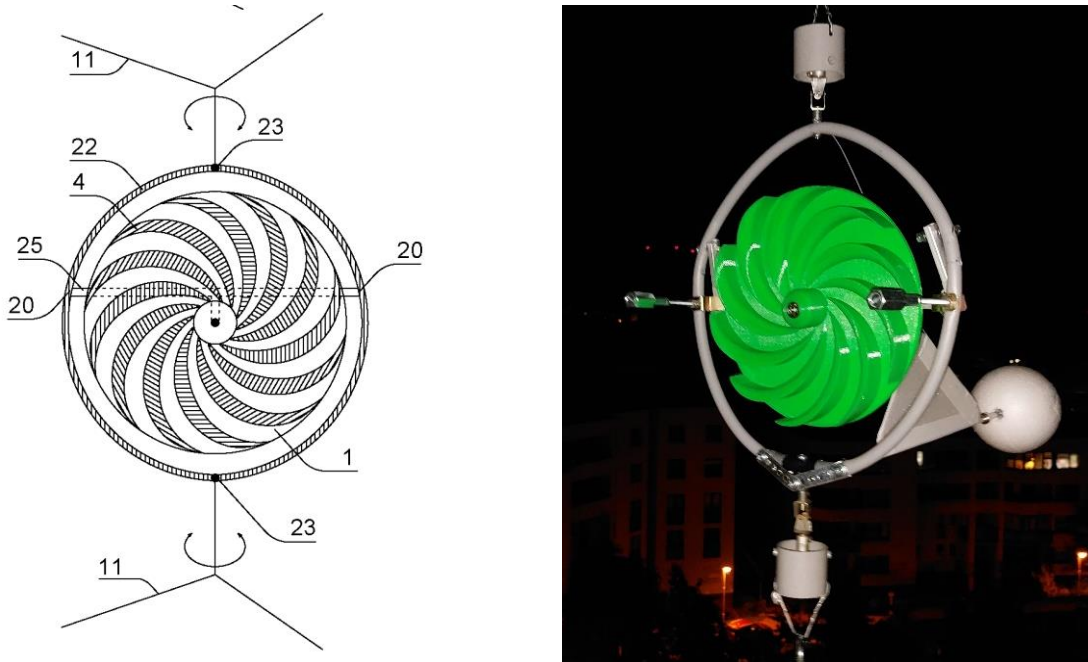

The composition of the rotating part of the turbine, the connection and shape of the leaves of the rotating plate **4** and the attachment of the generator **7** with the fitting of the pike **8** are identical as described in the first design type. Among the parts of the structure ensuring the position of the rotating parts in the correct position relative to the direction of the air flow in the horizontal plane, there are a frame ring **22** mounted in swivel hinges **23** fixed on

FIG. 19

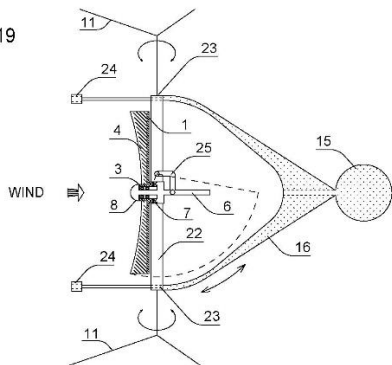

FIG. 20

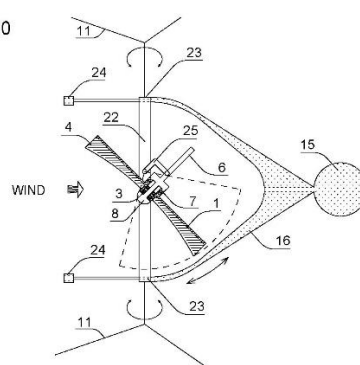
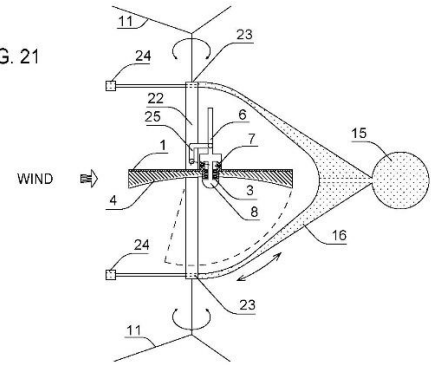

FIG. 21



supporting ropes **11** and a horizontal rotating structural rod **6** attached perpendicularly to the rod structure of the rope fastening, which is connected to the frame ring **22** by a swivel joint **20**. The rear surface direction indicator **16** and the load **24** are attached to the frame ring which balances the entire structure. The flat direction indicator **16** ensures the rotation of the flat axial wind turbine in the right direction, and the spherical direction indicator **15** is connected to it, which ensures the same and at the same time it stabilizes the horizontal movement. The supporting parts of the structure include the frame ring **22** and the supporting ropes **11**.

Description of the structure of a single-ring flat axial wind turbine with external stabilization of the rotating circular plate mounted pivotally to a support mast

(shown in view in Fig. 7, in cross-section in Fig. 8, in detail in Fig. 9 and in cross-section in Fig. 10)

The description of the structure of the flat axial wind turbine of this design type is the same as that given in the first design type, with the difference that the peripheral part of the rotating circular plate **11** is stabilized against transverse and circumferential deformations by adding a rotationally immovable support frame of the external stabilization of the circular plate **9**. This frame is rigidly connected to the horizontal rotating structural rod **6**. Stabilization is ensured through the peripheral wheels of the external stabilization of the circular plate **10** and the transverse wheels of the external stabilization of the circular plate **13**.

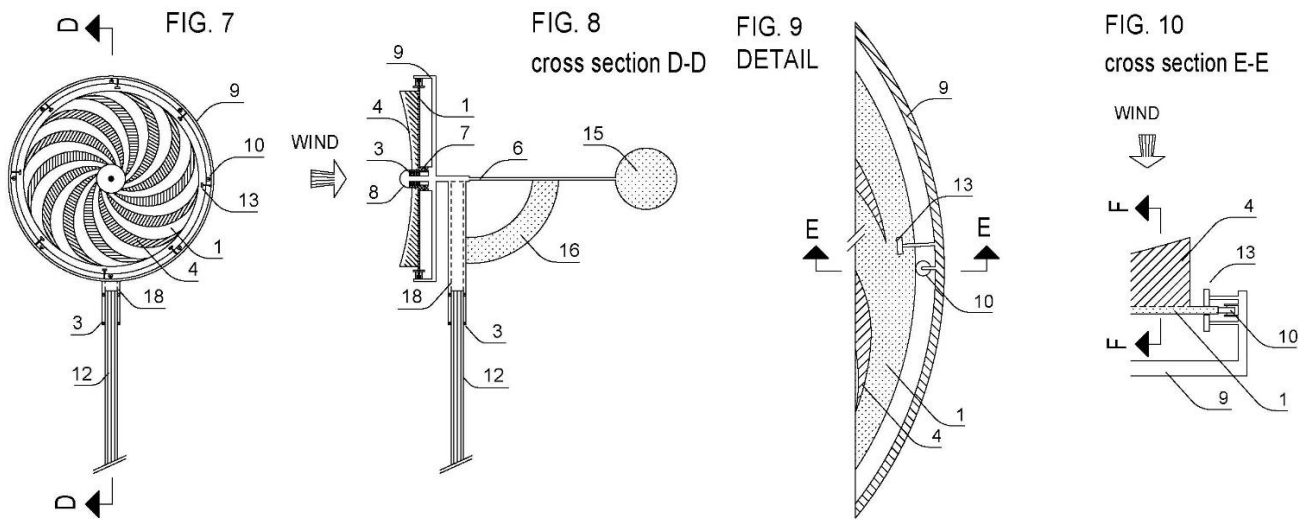

Description of the structure of a single-ring tilting flat axial wind turbine with a confusor mounted pivotally on supporting ropes

(shown in cross-section in Fig. No. 22)

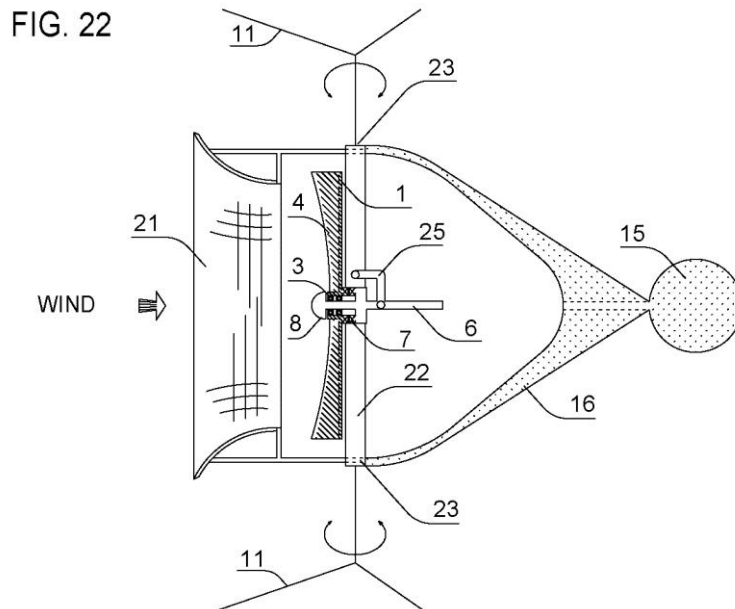

The description of the structure of the flat axial wind turbine in this example is the same as that of the suspended design types on the supporting ropes, with the difference that, in the part where the loads **24** are attached, a confusor **21** is attached, which directs and optimizes the air flow from a larger area, thus achieving greater efficiency of the rotor part of the turbine without increasing its diameter.

4. Protection of flat axial wind turbines

The protection of flat axial wind turbines against gales is done by an automatic tilting system, which, when the pressure on the rotating cone plate increases, deflects it to a position perpendicular to the wind, and when this pressure decreases and the wind speed decreases, it sets the rotating cone plate into the working position by the effect of its weight. Other ways of protecting flat axial wind turbines and deflecting them to a position perpendicular to the wind can be controlled electronically based on sensors recording the direction and strength of the wind. The flat axial wind turbines can be mounted rigidly on a mast or suspended from ropes in various groups. For larger flat axial wind turbines, the stability of the rotating circular plate is ensured by a support structure using an external stabilization frame and transverse and peripheral wheels.

5. Advantages of the flat axial wind turbine

The advantages of the flat axial wind turbine compared to the classically used propeller HAWT turbine are as follows:

- maintaining the same performance in reducing the diameter of the propeller in the case of a flat axial wind turbine with respect to the comparatively same used area of a classic propeller
- the creation of a suction effect around the circumference of the rotating plate where the air that transfers its kinetic energy to the rotating plate or two plates and loses its speed is removed and accelerated by the centrifugal force and the natural movement of the surrounding air
- the possibility of suspending the entire flat axial wind turbine on a rope, thereby obtaining greater variability in the location of the turbine and reducing the transmission of vibrations to the foundations
- increasing the speed of the generator by using two counter-rotating plates connected to one machine
- the use of inexpensive and available materials
- easy assembly from the pre-prepared smaller parts
- the environmentally friendly design that does not burden the environment by killing living creatures, producing noise and vibrations from high-speed moving external parts of the equipment
- the use of very strong wind and gusts of wind, as well as very weak air flow
- the prevention of visual disturbances on the landscape caused by the moving leaves of the wind turbines
- the suitability of use in urban development, because the rotating parts are compact and do not disturb the surroundings
- producing less noise due to lower air resistance in the direction of rotation of the plates

6. Use of the flat axial wind turbine

The flat axial wind turbine can be used to convert the kinetic energy of the wind into mechanical energy, for example as a driving force for generators, pumps, etc. The industrial applicability mainly consists in building an energy industry from renewable energy sources. Such a structure is also of great use in the supply of cheap electricity for the growing number of electric charging stations for the mobility of electric cars.

turbine axonometry

FIG. 13

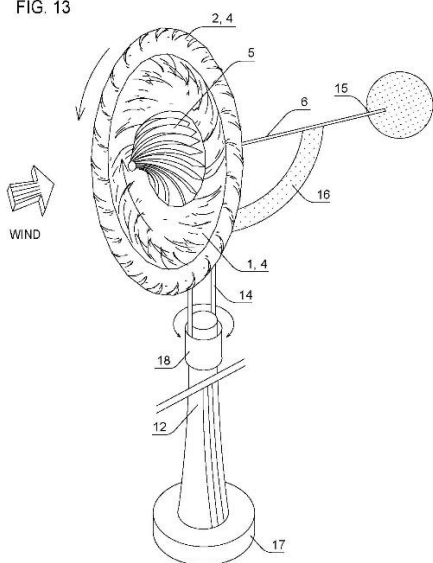

FIG. 14

